

Sensori con sfera in Rubino e stelo in carbonio o acciaio

Diametro sfera in Rubino	Dr.	1 - 2 - 3 - 4 mm.
Attacco stelo	As.	10 mm.
Filetto	M	M3 x 6 mm.
Lunghezza Stelo Fornibile	Ls.	da 15 a 30 mm.
Diametro Stelo	Ds.	2 mm.
Sensore Standard		L utile = 38 mm.

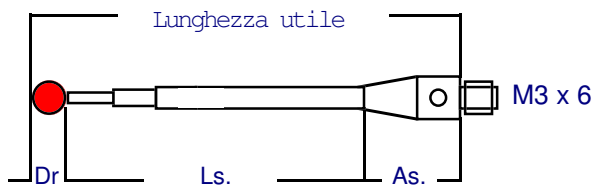

Lunghezza utile Dr. + Ls. + As.

Sensori a Stella

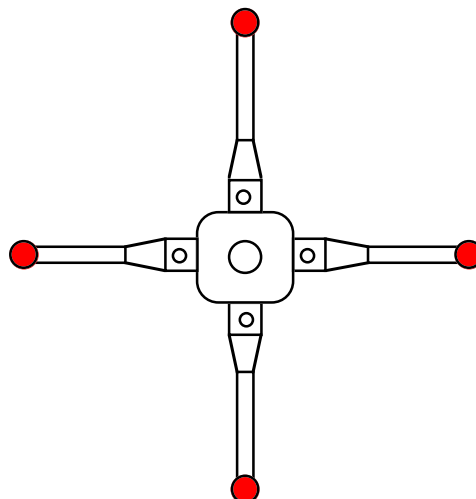
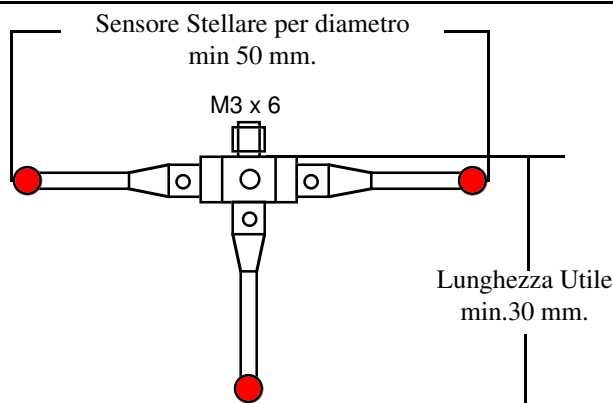

Centratore mod.BSP

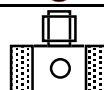

Sensori realizzati con palpatore semisferico in ceramica

Diametro Semisfera Ceramica	mm. 25
	mm. 30

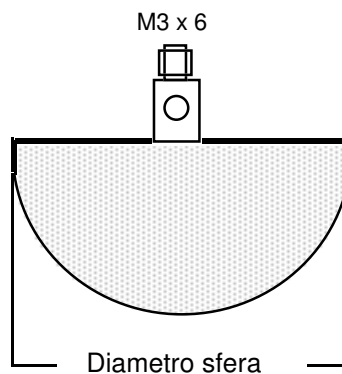

Sensori realizzati con Piattello palpatore a bordi sferici

Diametro Piattello in Ceramica	mm. 25 spessore 3
	mm. 30 spessore 3
	mm. 25 spessore 4
	mm. 30 spessore 4

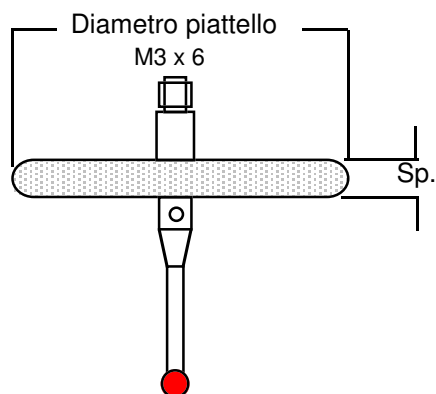

Per Sensori di tipo non Standard quotazioni su richiesta